

GaZILLION BUBBLES

BUBBLE STORM™

Ⓞ INSTRUCTIONS Ⓞ INSTRUCTIONS Ⓞ INSTRUCCIONES
Ⓞ BEDIENUNGSANLEITUNG Ⓞ INSTRUCTIES
Ⓞ ISTRUZIONI PER IL Ⓞ INSTRUÇÕES

1.



- Ⓞ Install 4 x AA batteries
- Ⓞ Mettre 4 piles AA
- Ⓞ Instala 4 pilas AA
- Ⓞ 4 x AA-batterien einlegen
- Ⓞ Instala 4 pilhas AA
- Ⓞ Instala 4 batterie AA
- Ⓞ Plaats 4 AA batterijen

2.

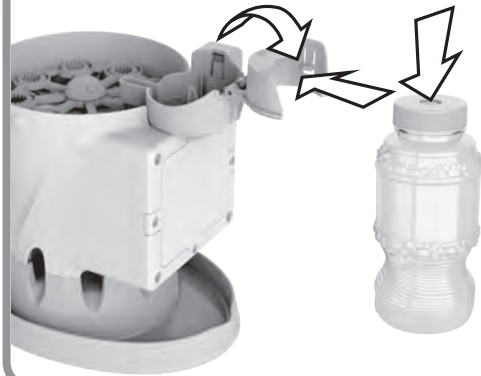

- Ⓞ Assemble
- Ⓞ Assemble
- Ⓞ Monta
- Ⓞ Zusammenbauen
- Ⓞ Monta
- Ⓞ Assembla
- Ⓞ Monteren

3.



- Ⓞ Flip bottle up to start.
- Ⓞ Faire pivoter la bouteille vers le haut pour commencer.
- Ⓞ Ponla boca abajo para empezar.
- Ⓞ Zum Starten Flasche umdrehen.
- Ⓞ Levanta a garrafa para começar.
- Ⓞ Metti la bottiglia a testa in giù per iniziare.
- Ⓞ Draai fles omhoog om te beginnen.

4.



- Ⓞ Flip bottle down to stop.
- Ⓞ Faire pivoter la bouteille vers le bas pour arrêter.
- Ⓞ Ponla de pie para parar.
- Ⓞ Zum Beenden Flasche zurückdrehen.
- Ⓞ Baixa a garrafa para parar.
- Ⓞ Metti la bottiglia a testa in su per interrompere.
- Ⓞ Draai fles omlaag om te stoppen.

5.



- Ⓞ Recycle solution
- Ⓞ Recycle la solution
- Ⓞ Recicla la solución.
- Ⓞ Lösung recyceln
- Ⓞ Reutilize a solução
- Ⓞ Riciclare la soluzione
- Ⓞ Recycle-oplossing

6.

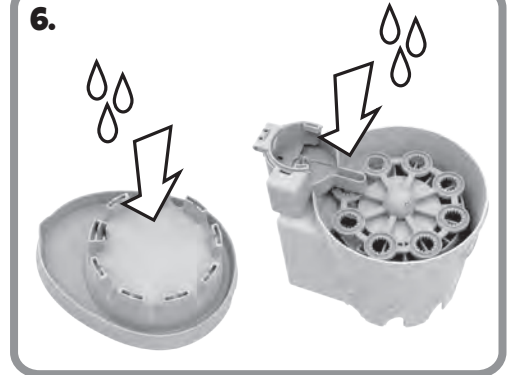

- Ⓞ Cleaning: Rinse tray and top dispenser. Do not submerge top.
- Ⓞ Nettoyage : rincer le bac et le dévidoir supérieur. Ne pas immerger la partie supérieure.
- Ⓞ Mantenimiento: aclarar el depósito inferior y el dispensador superior.
- Ⓞ Reinigung: Becken und Oberteil ausspülen. Oberteil nicht unter Wasser tauchen.
- Ⓞ Limpeza: Passar o tabuleiro e o dispensador superior por água. Não submergir o topo.
- Ⓞ Pulizia: risciacquare la vaschetta e l'erogatore superiore. Non sommergere la parte alta.
- Ⓞ Schoonmaken: Spoel bakje en dispenser bovenop af. Houd de bovenkant niet onder water.

* All instruction sheets must be retained since it contains important information.
 * Toutes les fiches d'instructions contiennent des informations importantes et doivent donc être conservées.
 * Debe conservar todas las hojas de instrucciones porque contienen información importante.
 * Alle Anleitungen müssen aufbewahrt werden, da sie wichtige Informationen enthalten.
 * Alle instructiebladen moeten worden bewaard, omdat ze belangrijke informatie bevatten.
 * Tutte le istruzioni vanno conservate, in quanto contengono informazioni importanti.
 * Todos os manuais de instruções devem ser preservados, pois contém informações importantes.

Ⓞ © 2024 Funrise, inc. All rights reserved.
 Ⓞ © 2024 Funrise, inc. Tous droits réservés.
 Ⓞ © 2024 Funrise, inc. Todos los derechos reservados.
 Ⓞ © 2024 Funrise, inc. Alle rechte vorbehalten.
 Ⓞ © 2024 Funrise, inc. Tutti i diritti riservati.
 Ⓞ © 2024 Funrise, inc. Todos os direitos reservados.
 Ⓞ © 2024 Funrise, inc. Alle rechten voorbehouden.